

Flow and heat transfer in a closed loop thermosyphon

Part II – experimental simulation

J C Ruppertsberg

R T Dobson

Department of Mechanical Engineering, University of Stellenbosch, South Africa

Abstract

A closed loop thermosyphon is an energy transfer device that employs thermally induced density gradients to induce circulation of the working fluid thereby obviating the need for any mechanical moving parts such as pumps and pump controls. This increases the reliability and safety of the cooling system and reduces installation, operation and maintenance costs. These characteristics make it a particularly attractive option for the cavity cooling system of the Pebble Bed Modular Reactor (PBMR). Loop thermosyphons are however, known to become unstable under certain initial and operating conditions. It is therefore necessary to conduct an experimental and theoretical study of the start-up and transient behaviour of such a system. A small scale test loop was built representing a section of a concept cooling system. A number of representative yet typical experimental temperature and flow rate curves for a range of initial and boundary conditions were generated, plotted and are given as a function of time. These curves show that oscillatory temperature and flow occurred that was dependent on the differing design and operating conditions. A number of theoretical modelling and actual cooling system design problem areas were identified. These problem areas need to be addressed if more accuracy is required to capture the erratic and ostensibly chaotic heat transfer behaviour of the loop.

Keywords: closed loop two-phase thermosyphon heat pipe, two-phase flow, experimental evaluation, transient analysis

1. Introduction

A closed loop thermosyphon is an energy-transfer device capable of transferring heat from a heat source to a separate heat sink over a relatively long distance. It can be visualised as a vertically orientated loop consisting of pipes that contain a working fluid. If the one side of the loop is heated and the other cooled, the average density of the fluid in the heated side is less than that of the cooled side. A hydrostatic pressure difference, as a result of this thermally induced density gradient between the hot and the cold sides, drives the fluid flows around the loop. This eliminates the need for any mechanical moving parts such as pumps and pump flow controls.

These devices are thus particularly suitable for cooling applications (as in nuclear reactor technology for example) where reliability and safety are of paramount importance. For these reasons the use of natural circulation closed loop thermosyphons are to be considered for the cooling of the reactor cavity of a Pebble Bed Modular Reactor (PBMR).

A concept drawing of a potential reactor cavity cooling system (RCCS) for the PBMR as proposed by Dobson (2006) is given in Figure 1. In this concept the RCCS may be represented by a number of axially symmetrical elements: the reactor core, reactor pressure vessel, air in the cavity between the reactor vessel and the concrete structure, the concrete structure, a heat sink situated outside the concrete structure, and a number of closed loop thermosyphon heat pipes with the one vertical leg in the hot air cavity and the other leg in the heat sink. The heat pipe loops are spaced around the periphery of the reactor cavity at a pitch angle θ . Vertical fins are attached to each length of the heat pipe in the cavity to shield the concrete structure from radiation and convection from the reactor vessel through the gap between the pipes and to conduct the heat to the pipes.

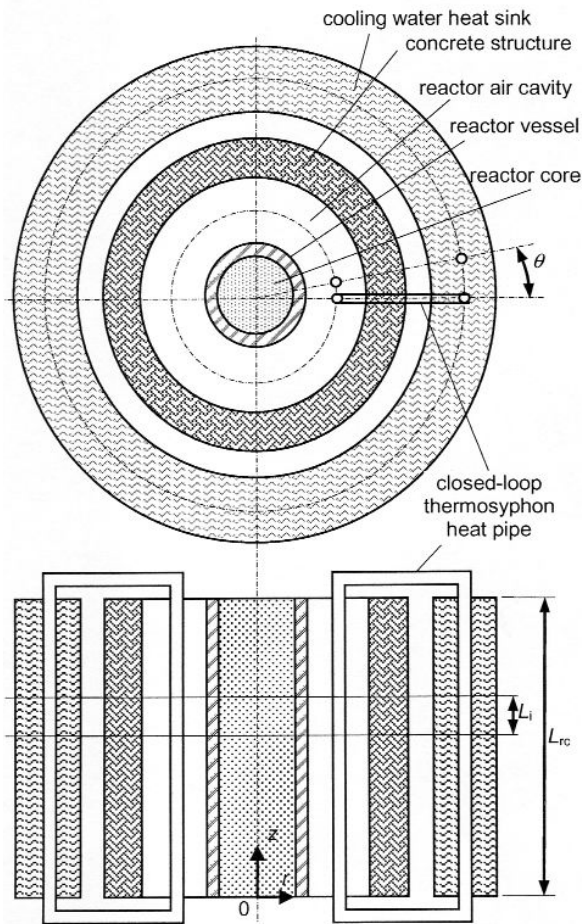

Figure 1: Schematic representation of the axially symmetrical RCCS showing equally spaced closed loop thermosyphon heat pipes spaced around the periphery of the reactor at a pitch angle θ

Loop thermosyphons are however, known to become unstable under certain initial and operating conditions. It is therefore necessary to undertake a thorough investigation of the operation of such a system. Although a theoretical simulation of a suitable loop has been developed (Dobson and Ruppertsberg, 2007) its validity needs to be established experimentally. The objective of this paper will thus be to present an experimental loop that may be used to test the validity of the theoretical simulation model. The experimental loop is shown in Figure 2. The basic shape is based on published literature, a brief survey of which is given in section 2. Details of the experimental set-up are given in section 3, some of the results are shown in section 4 and finally conclusions are drawn in section 5.

2 Literature survey

A considerable amount of research has been done relating to natural circulation loops. Natural circulation loops find widespread use: in the chemical process industry as thermosyphon reboilers (Arneith and Stichlmair, 2001; Chexal and Bergles, 1986), in

energy conservation as solar water heaters and waste heat recovery (Cheng *et al*, 1982; Chen *et al*, 1991, and Yilmaz, 1991), in the electronics industry (Khodabandeh and Palm, 2002) but particularly in the nuclear industry as passive heat removal systems under accident conditions as well as for removal of parasitic heat loss during normal operation (IAEA, 2000; Sha *et al*, 2004).

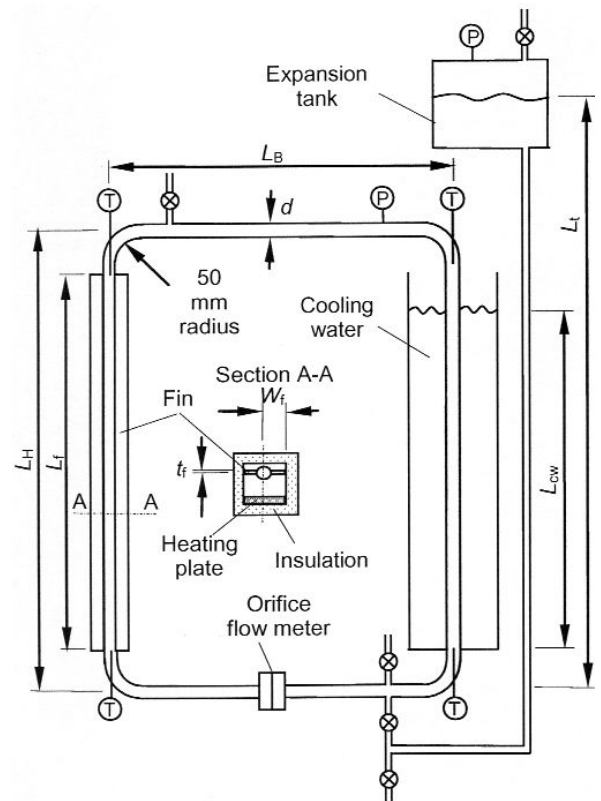

Figure 2: Schematic representation of a natural circulation experimental loop showing important dimensions

The theoretical basis on which a natural circulation loop can be simulated is given by Dobson and Ruppertsberg (2007). In this survey, however, mainly experimental studies of two-phase loops are considered; thereby acknowledging much of the research work that has helped influence the basic design and experimental procedure of the set-up described in this paper.

Hsu *et al.* (1998) considered the natural circulation and flow termination during a *small break* loss of a coolant accident in the hot leg U-bend of a light water reactor (LWR). Scaling effects were investigated using a nitrogen-water two-phase system with a pipe diameter of 50 mm and a hot leg riser height of 5.5 m. Two-phase flow oscillations were observed near flow termination and the experiments demonstrated that the natural circulation termination occurs when there is insufficient hydrostatic head in the down comer side. As long as the two-phase level in the hot leg can be raised to the top of the loop, the carryover flow can be re-established.

Liu *et al.* (2000) intends to design an effective finned tube evaporator to form part of a containment cooling system. In order to develop reference data, experiments were performed using a two phase loop with a vertical 38 mm inside diameter smooth copper pipe of about 2 m high. The lower portion of the loop was heated using a separate steel pressure vessel in which steam could be generated using 27 kW electrical water heating elements. The air/helium could be introduced into the vessel to simulate the effect of non-condensable gasses on the condensation heat transfer coefficients between steam generated in the reactor containment structure and the outside of the evaporator, during post accident conditions.

Ohashi *et al.* (1998) undertook a preliminary study of the use of a two-phase natural circulation loop concept to remove decay heat from a high temperature reactor (HTR). The loop was evacuated and charged with water as the working fluid. Temperatures at different levels in the condenser could be measured but loop dimensions were not given. The loop was heated using an electrical heating element wrapped around the outside of the evaporator. The condenser portion of the loop was cooled with water using a forced-flow tube-in-tube heat exchanger. It was shown that the temperature of the working fluid increased in step with the increase in heat input. For a given input it was found that the temperature along the length of the tube varies very little, approximately 2-3 °C. Introducing nitrogen gas into the system however, gives a large variation of approximately 60 °C. The authors call this a variable conductance heat pipe. Through the proper selection of non-condensable gas, initial amount and pressure, it is possible to have passive temperature control.

Jiang *et al.* (1995) investigated the thermohydraulic behaviour of natural circulation using a test loop with a riser of 3 m to simulate the geometry and system design of the primary loop of a 5 MW nuclear reactor. Three types of instability, namely geysering, flashing and low steam quality density wave oscillations need to be addressed in the start-up process from atmospheric to operating conditions. Experiments show that flashing occurs in the long, non-heated riser at low operating pressures, and geysering and flashing instabilities occur when starting up from atmospheric conditions. A method was devised to reach operating conditions whilst bypassing all instability. This method required control of the system pressure and heat flux.

Stauder and McDonald (1986) studied a two-phase thermosyphon loop with a separator, allowing the liquid to re-circulate to the bottom of the evaporator so that only steam was condensed in the higher positioned condensing section of the loop. It was also found that a wall superheat ($T_{\text{wall}} - T_{\text{sat}}$) of more than 13°C was necessary to initiate nucleate

boiling but once boiling had commenced (because of the superior heat transfer coefficient associated with nucleate boiling), the wall superheat dropped to approximately 4°C.

Many experimental studies have also been undertaken to investigate loop instabilities. Wu *et al.* (1996) studied chaotic oscillations in a two phase natural circulation loop. It was found that power input and inlet sub-cooling has a large effect on the oscillating behaviour of the loop. Wang and Pan (1998), using Taguchi methods to identify the required experiments, share these conclusions but add that flow restrictions and compressible volumes are also factors influencing stability.

Koizumi and Ueda (1994) studied dry-out in a natural circulation two phase loop. Results indicate that dry-out occurs in the annular flow region and that the dry-out heat flux is primarily dependant on the circulation flow rate. Hirashima *et al.* (1994) studied the flow in the evaporator of a *separate type* thermosyphon. It was shown that the flow and heat transfer behaviour was influenced by the heater type, pipe diameter, heat flux and liquid level.

3. Experimental set-up

The experimental loop as shown in Figure 1 consists of 25.4 mm inside diameter pipes; aluminium for the vertical heating/cooling sections and stainless steel for the horizontal sections.

The heat source was a 1.5 m high and 145 mm wide stainless steel plate representing a section of the heated pressure vessel radiating heat to the concrete structure. Nine 1.3 kW spiral electrical stove heating elements were attached to the plate, giving a total heating capacity of 11.7 kW. The power to the heating elements was controlled using individual on/off timer switches. This made it possible to create a temperature profile along the plate. Rectangular fins, 1.5 m high, 60 mm long and 1.6 mm thick, are welded along the length of the pipe in the portion of the loop adjacent to the heating plate. The heating plate and fins were spaced 100 mm apart. The evaporator section and heat source was situated in a heating chamber that was insulated with a ceramic wool blanket.

The temperature distribution along the heating plate was measured with five equally spaced K-type thermocouples. The fin temperature distribution was measured using six equally spaced T-type thermocouples. Four 1.6 mm T-type thermocouple probes inserted at each bend of the loop measured the working fluid temperatures.

The accuracy of the thermocouples was verified by testing the thermocouples against a platinum resistance thermometer. The tests indicated all the thermocouples measured within an acceptable accuracy range with little variability between thermocouples of the same batch of material.

The flow rate of the working fluid was measured using a calibrated orifice plate and a HBM differential pressure gauge and bridge amplifier.

4. Experimental results

Figure 3 shows a typical set of experimental results for the heating plate, fin and working fluid temperatures and mass flow rate. Figure 3(a) shows the heating plate temperatures at different positions along the plate as a function of time. The power to the heater plate was maintained for about 3100 s before being switched off. Figure 3(b) shows the different fin temperatures; Figure 3(c) the working fluid temperatures, and Figure 3(d) shows the mass flow rate.

Figure 3(c) shows the temperature rise of the working fluid. The evaporator top temperature $T_{e,t}$ increases steadily to a peak of 94°C at 2 150 s, thereafter for about 150 s it decreases slightly until boiling starts to occur at 2300 s at the top of the evaporator, where the pressure is at its lowest and manifests itself as a periodic temperature oscillation varying between 90 and 100°C. At 2 150 s the bulk fluid temperature peaks at 94°C (as indicated in Figure 3(c)), the fin temperature exceeds 100°C at this point and thus the wall temperature must also exceed the saturation temperature of the bulk fluid, and hence boiling occurs at the wall. The driving force, as a result of the pressure difference between the heated and cooled portions, increases and hence so too does the mass flow rate. As a result of the now cooler fluid flowing over the thermocouple, its temperature drops. The mass flow rate slows down slowly until this sub-cooled boiling at the wall changes to bulk boiling throughout the fluid at 2 300 s.

The temperatures at the top of the condenser at 2 300 s starts to oscillate (it is not visible in the figure as it is shadowed by the evaporator top temperature) with an amplitude of 1°C, at the bottom it oscillates with a larger amplitude of up to 5°C. These oscillations are due to the mass flow rate oscillating back and forth. At the top, warm working fluid flows over the thermocouple in the positive direction then returns, without reaching the water tank below and is now only slightly cooler due to the relatively poor convection heat transfer to the air. At the bottom the working fluid flows over the thermocouple and afterwards continues to be cooled by the water tank, much more than is possible with the convection to the air. Thus when the mass flow reverses its direction, a bigger temperature difference at the bottom compared with the top occurs.

In Figure 3(d) it is seen that the mass flow rate increases to a peak of 2 g/s at 650 s, thereafter decreasing slightly until boiling occurs at 2300 s when the flow meter reads a relatively large change in the flow from the one direction to the other.

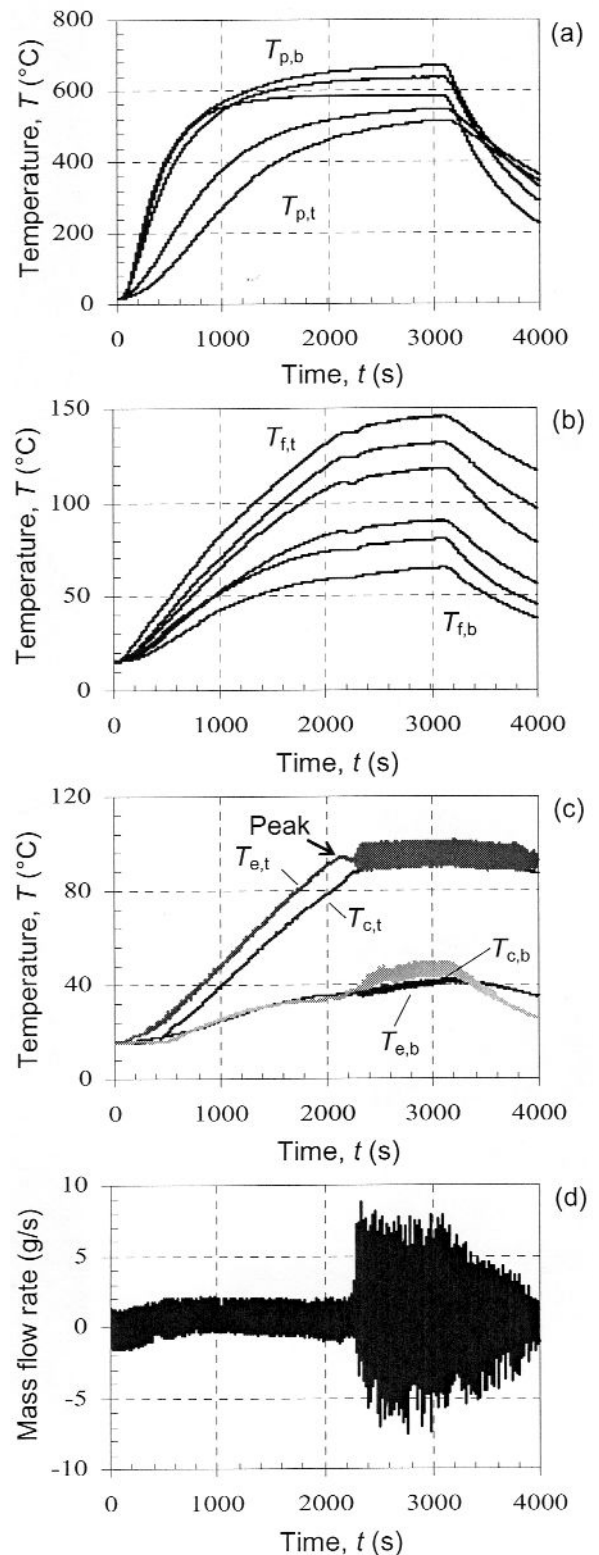

Figure 3. (a) Heating plate temperatures (b) Fin temperatures, (c) Working fluid temperatures (d) Mass flow rate.

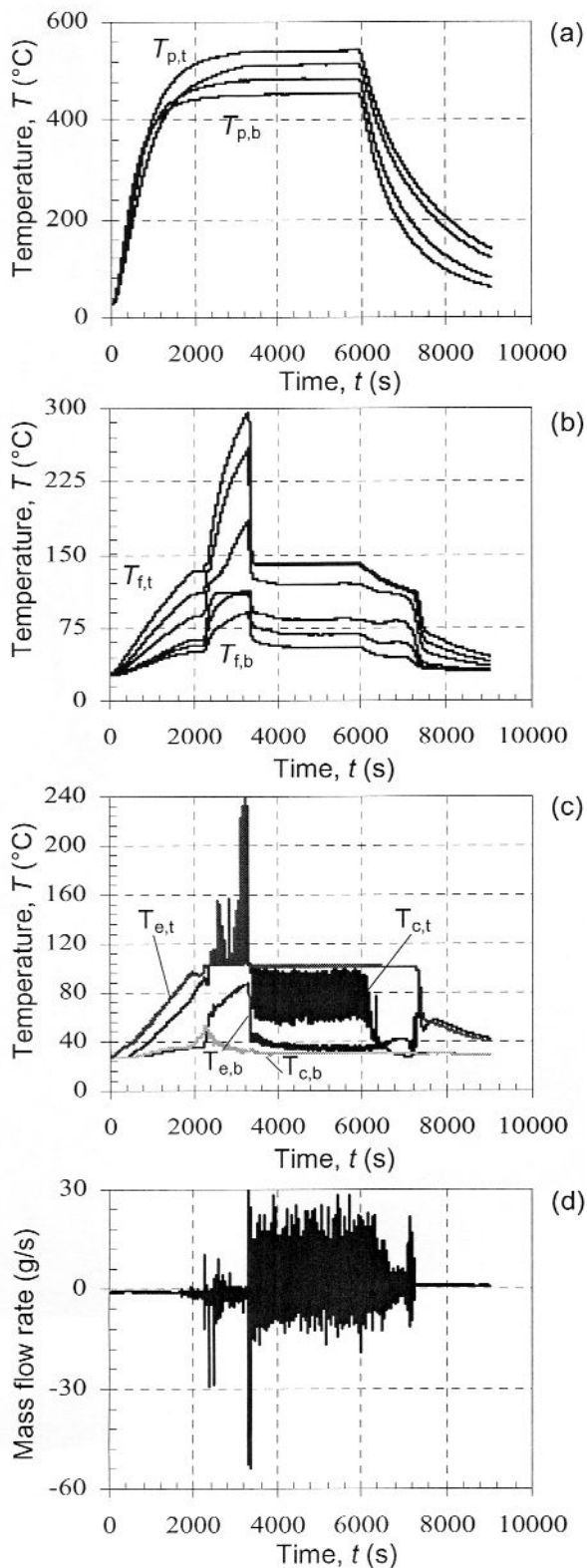

Figure 4: (a) Heating plate temperatures (b) Fin temperatures (c) Working fluid temperatures (d) Mass flow rate

When the power to the heating elements is switched off at 3 000 s, the amplitude of the oscillations decrease.

Figure 4 shows another set of results for a slightly different heating plate temperature profile. In contrast to the results reflected in Figure 3, a large increase in fin temperature is seen to occur when boiling starts. The top portion of the loop is filled with vapour as evidenced by the condenser thermocouple measuring constantly above 100°C , after boiling begins. The smaller heat transfer rate associated with convective heat transfer to the vapour (as opposed to liquid) causes local superheating of the vapour. Figure 4(c) shows fin-temperatures well above 200°C . Since the thermocouple in the loop is surrounded by vapour only, it is not unreasonable to expect the measured thermocouple temperature to be approximately the average of the wall and vapour temperatures. The wall being heated by a radiation source of above 500°C and a fin at the top is seen to be approaching 300°C .

In order to prevent overheating the portion of the condenser not in contact with the water in the tank was cooled by a steady stream of water. This had the effect that the evaporator top temperature stopped its oscillations, but the condenser side temperature now started to oscillate (Figure 4c). This oscillation can be due to two reasons. Firstly, there is the liquid carried over by the vapour flow. Liquid and vapour of different temperatures come alternatively into contact with the thermocouple. The second possibility is the change in water level in the condenser caused by the carry over and the vapour that condenses. This could cause the thermocouple to be periodically immersed in hot water from the evaporator and then cooler water rising from the bottom of the condenser section.

When the power input was decreased, the mass flow rate started to decrease allowing a temporary increase in temperature at the bottom of the evaporator as the fluid spends a little more time in the heating section. At the same time, the temperature at the top of the condenser dropped sharply (Figure 4c). The stream of water flowing down the length of pipe above the cooling water level in the tank resulted in a large heat transfer rate, cooling this slower flow to approximately 30°C where the mass flow rate reached its minimum value. This however, caused an increase in the density gradient again and the mass flow rate increased. As the mass flow rate started to increase again, the reverse happened to the temperatures. At one point the combination of lower heat input and increased flow rate does not allow for boiling anymore and the single phase mass flow rate can once again be identified in the graph. The liquid filled loop caused the temperatures measured at the two top thermocouples to be approximately the same with the condenser side being slightly higher. Consider the loop at the point

power is switched off. The liquid in the hot leg flows to the cold leg, the new liquid coming into the hot leg at approximately the same temperature as before but is heated less than before causing this difference in the two temperatures.

The difference in boiling behaviour between the two tests might be attributed to the atmospheric temperatures. The experiments that correspond to that of Figure 4 were conducted during the summer months where the average temperature of the surroundings was 10 – 15°C higher than that experienced during the winter month tests characterized by Figure 3. This reduced losses to the atmosphere and increased the initial water temperature in the cooling tank.

5. Discussion and conclusions

An important objective of the experimental loop is to assist in determining the accuracy of the theoretical model given by Dobson and Ruppertsberg (2007). Figure 5 shows the theoretical results superimposed on the experimental results of Figure 3. For the theoretical calculations the same heating plate temperature profile shown in Figure 3 was used, the evaporator and condenser heat transfer coefficients were 4 000 W/m²K and 8000 W/m²K respectively, and the heating plate emissivity was taken as 0.1 whilst for the fin it was taken as 0.5. In both Figures 5(a) and (b) it is seen that the theoretical temperatures correspond reasonably well with the experimental temperatures. The time predicted by the theoretical model to reach the operating temperature is however, 50% shorter than for the experimental value of 2 000 s. This could be due to the theory not being able to accurately determine the rate at which the insulated shroud absorbs heat and in turn loses it to the environment.

The shortcomings identified in the theoretical model are:

- Only steady-state correlations for single and two-phase heat transfer coefficients were found in the literature; whereas in the actual experimental loop it is clear that a type of oscillating flow occurs. In trying to simulate the experimental loop theoretically it would appear that significantly higher correlating heat transfer coefficient values, than are given by existing correlations, are needed.
- To accurately predict the heating response time, careful attention must be paid to the theoretical model in order to accurately simulate the heating plate, insulating materials as well as the supporting structures. Also, accurate surface and material heat transfer properties, such as emissivity and thermal conductivity, are needed.

Another important objective was to use the experimental model to assist in identifying shortcomings with the proposed physical layout of a PBMR reactor concept reactor cavity cooling system. During

the testing the following shortcomings became apparent:

- It was not possible to accurately verify experimentally whether the heat input balanced the heat removed by the cooling water. For instance, it is difficult to accurately measure the temperature distribution in a naturally convective stratifying tank of water; neither is it easy to measure the heat transfer rate due to both radiation and convection in the space between the heating plate and the fin. It was also not possible to measure liquid carryover from the heated to the cooled legs of the loop during two-phase flow.
- Breaking of seals due to differential expansion of the pipe and supporting structures as a result of temperature gradients needs to be carefully considered in order to circumvent leaking.

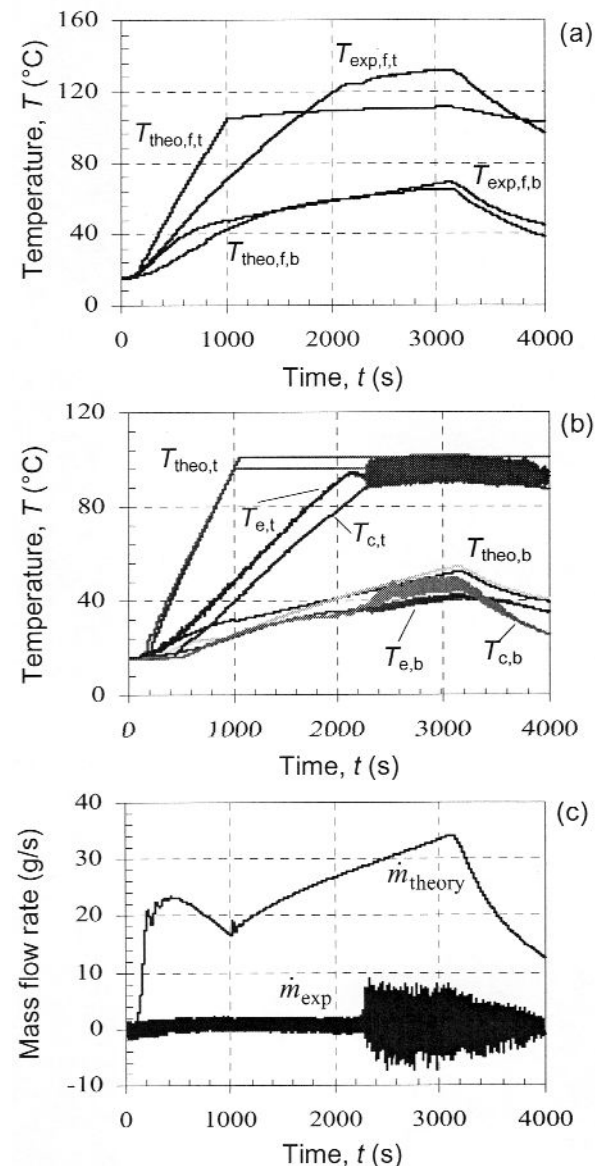

Figure 5. (a) Fin temperatures, (b) Working fluid temperatures (c) Mass flow rate

- Convection in the air-space between the heating plate and the fin was complex. Heat transfer correlations showed that natural convection should have taken place in this space enclosed by the heating plate, the vertical fin and the top cover plate of the heating chamber. This was found not to be so as significant stratification occurred resulting in a larger than expected variation in the temperature between the top and the bottom ends of the air space. This was also substantiated by the relatively large temperature variation along the fin as shown, for instance, in Figure 3(b).
- In Figure 5(c) it is seen that the differential pressure transducer exhibited a significantly large noise level as well as a large difference between the theoretical and experimental flow rates. This indicates the use of a more sensitive transducer to accurately measure the flow rate.
- The flow and temperature of the working fluid in a closed two phase loop thermosyphon is seen to be complex and ill-defined and is characterized by seemingly chaotic and erratic velocity and temperature oscillations. This is especially so when a transition from single to two-phase flows, or, from two-phase back to single phase, occurs. Changes in operating conditions may also result in significant variations of the flow and temperature behaviour.

Nomenclature

d	diameter, m
L	length, m
\dot{m}	mass flow rate, kg/s
P	pressure, Pa
T	temperature, °C
W	Width, m
θ	Angle, °

Subscripts

B	Breadth
b	bottom
c	condenser
cw	cooling water
e	evaporator
exp	experimental
f	fin
H	height
p	plate
rc	reactor core
sat	saturated
t	tank, top
theo	theory

Acknowledgement

The support and assistance given by PBMR (Pty) Ltd is hereby acknowledged.

References

- Arneth, S. and Stichlmair, J., Characteristics of thermosyphon reboilers, *Int. J. Therm. Sci.*, 2001, Vol. 40, pp. 385-391.
- Chen K.S., Tsai, S.T., & Yu, W.T., Experimental study of the heat transfer characteristics of a two-phase double-loop thermosyphon, *Exp. Heat Transfer*, 1991, Vol. 4, pp. 171-188.
- Cheng, K.C., Morioka I., Ichimiya K., Sadler G.W., Experimental study of a two-phase thermosyphon system, *Alternative Energy Sources* (ed. Vezirođlu, T.N.), 1982, Vol. 1, Solar Collector Storage, Ann Arbor, pp. 151-170.
- Chexal, V.K. and Bergles, A.E., Two-phase instabilities in a low pressure natural circulation loop, *AIChE Symposium Series*, 1986, Vol. 69, No. 131, pp. 37-45.
- Dobson, R.T., A novel closed loop thermosyphon heat pipe reactor cavity cooling system for a pebble bed modular reactor, *8th Int. Heat Pipe Symp.*, 24-27 Sept., Kumamoto, 2006, pp. 397-384.
- Dobson, R.T. and Ruppertsberg, J.C. Flow and heat transfer in a closed loop thermosyphon Part I –Theoretical simulation, *Journal of Energy Southern Africa*, 2007, Vol. 18 No. 4, pp 32-40.
- Hirashima, M., Kawabata, K., Negishi, K., Experimental study on a separate type thermosyphon, *Wärme- und Stoffübetragung*, 1994, Vol. 29, pp. 479-486.
- Hsu, J-T., Ishii, M. & Hibiki, T., Experimental study on two-phase natural circulation and flow termination in a loop, *Nucl. Eng. Design*, 1998, Vol. 186, pp. 395-409.
- IAEA, Heat transport and afterheat removal for gas cooled reactors under accident conditions, (Electronic version, www.IAEC), TECDOC-1162, 2000, IAEA, Vienna.
- Jiang, S.Y., Yao M.S., Bo J.H. & Wu S.R., Experimental simulation study on the start-up of the 5 MW nuclear heating reactor, *Nucl. Eng. Design*, 1995, Vol. 158, pp. 111-123.
- Koizumi, Y. and Ueda, T., Study on dry-out heat flux of two-phase natural circulation, *Proc. 10th Int. Heat Transfer Conf.* Brighton, 1994, pp. 485-490.
- Khodabandeh, R. and Palm, B., Influence of system pressure on the boiling heat transfer coefficient in a closed two-phase thermosyphon loop, *Int. J. Therm. Sci.*, 2002, Vol. 41, pp. 619-624.
- Liu, H., Todreas, N.E. & Driscoll M.J., An experimental investigation of a passive cooling unit for a nuclear plant, *Nucl. Eng. Design*, 2000, Vol. 199, pp. 243-255.
- Ohashi, K., Hayakawa, H., Yamada, M., Preliminary study on the application of the heat pipe to the passive decay heat removal system of the modular HTR, *Prog. Nucl. Energy*, 1998, Vol. 32 No. 3/4, pp. 587-594.

- Sha, W.T., Chien T.H., Sun J.G., Chao B.T., Analysis of large-scale tests for AP-600 passive containment cooling system, *Nucl. Eng. Design*, 2004, Vol. 232, pp. 197-216.
- Stauder, F.A., McDonald, P.E., Experimental study of a two-phase thermosyphon-loop heat exchanger, *ASHRAE Transactions*, 1986, Vol. 92 No. 2a, pp. 486-494.
- Wang, S.B., Pan, C., Two-phase flow instability experiment in a natural circulation loop using the Taguchi method, *Exp. Thermal Sci.*, 1998, Vol. 17, pp. 189-201.
- Wu, C.Y., Wang, S.B. & Pan, C., Chaotic oscillations in a low pressure two-phase natural circulation loop under low power and high inlet sub cooling conditions, *Nucl. Eng. Design*, 1996, Vol. 162, pp. 223-232.
- Yilmaz, T. Computer simulation of two-phase flow thermosyphon solar water heating system, *Energy Convers. Mgmt*, 1991, Vol. 32 No. 2, pp. 133-144.

Received 20 February 2007; revised 6 August 2007